

DROP LENSES

Models 305, 306, 315 and 316

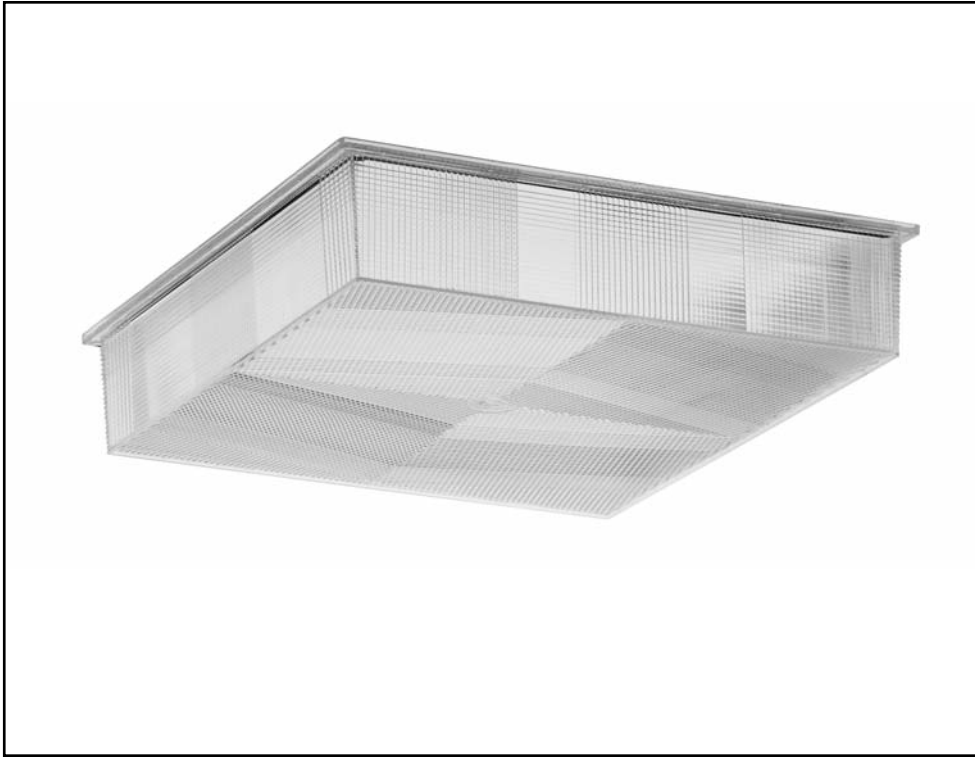

Model 305

Description

These 12 x 12 inch lenses have a 2.5 inch depth and precise optics, making them excellent for use in relatively low mounting height installations where brightness and glare control are important considerations. They are available in two configurations. Horizontal—for use as a drop lens in area and canopy lighting. Vertical—for wallmount and tunnel lighting. Models 306 (horizontal) and 316 (vertical) are molded of polycarbonate for use in areas where vandal resistance is required. Models 305 (horizontal) and 315 (vertical) are molded of ultraviolet stabilized acrylic for high efficiency in applications where ambient heat is not excessive.

Lamp Data

These lenses are primarily used with up to 175W HID lamps. Proper reflector and luminaire design is required to avoid detrimental internal reflections and high temperatures. Thermal testing should be conducted on each luminaire with the proposed light source in its selected position to confirm lamp size suitability, or to predict service life of the lens.

Ordering Information

Please call 877-257-5841 for price and delivery. Typical lead time is four to six weeks.

Service Life

The service life of acrylic refractors is virtually unlimited when used within the recommended temperature limit. Polycarbonate refractors are subject to yellowing especially when used with high ultraviolet output light sources; this effect is enhanced at high temperatures.

Notice

A.L.P. Lighting Components, Inc. assumes no responsibility for suitability of luminaires and applications. The use of our molded products at excessive temperatures with high UV output light sources will cause degradation of the material. Information regarding the use of lenses and refractors with Metal Halide lamps can be found in the Products/Technical Resources section of our web site at www.alplighting.com. *See second page for important UL information.

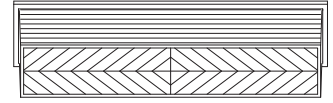

Models 305, 306, 315 and 316

Dimensions: 12" x 12"
Depth: 2.5"

STREET AND AREA
LIGHTING APPLICATIONS

TYPE II AND TYPE V
DISTRIBUTIONS

Models 305 and 306
Short-cutoff, Type II
Efficiency: 53.17%
Arc Tube Voltage Rise = 2.9

Materials: Acrylic and Polycarbonate



Models 305, 306, 315 and 316

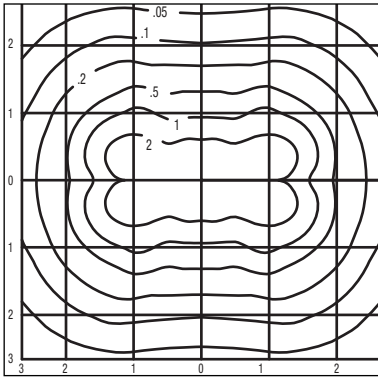

Photometrics

While the exact photometrics are dependent on the luminaire design, a few generalizations are possible. Models 305 and 306 produce a symmetrical square pattern when used with a curved reflective sheet and the horizontal lamp and socket set in the "A" position. By rotating the lens 90° and locating the horizontal lamp and socket in the "X" position, an asymmetrical rectangular pattern is produced as shown at left (ITL41903). Models 315 and 316—the lamp must be horizontally oriented in the upper third of the lens' vertical profile. The reflector shape can be a simple curved sheet or a parabolic cylinder contour. Individual luminaire performance depends on the lamp center position and the reflector design chosen. Each luminaire design should be individually tested for proper classification. Please visit our web site for additional photometric data.

Report Number: ITL41903
 Total Luminaire Efficiency = 53.17%
 IES Classification: Short-cutoff, Type II
 Arc Tube Voltage Rise = 2.9

Materials

See the LexaLite® brand price list for current part numbers and material offerings. Up-to-date and detailed material specifications can be found in the Products/Technical Resources section of our web site at www.alplighting.com.

UvaLex® is LexaLite's proprietary treatment to retard yellowing in ultraviolet environments and is standard on these polycarbonate refractors.

When using acrylic Models 305 and 315, the surface temperature of the lens should not exceed 80°C. When using polycarbonate Models 306 and 316, the surface temperature of the lens should not exceed 90°C.

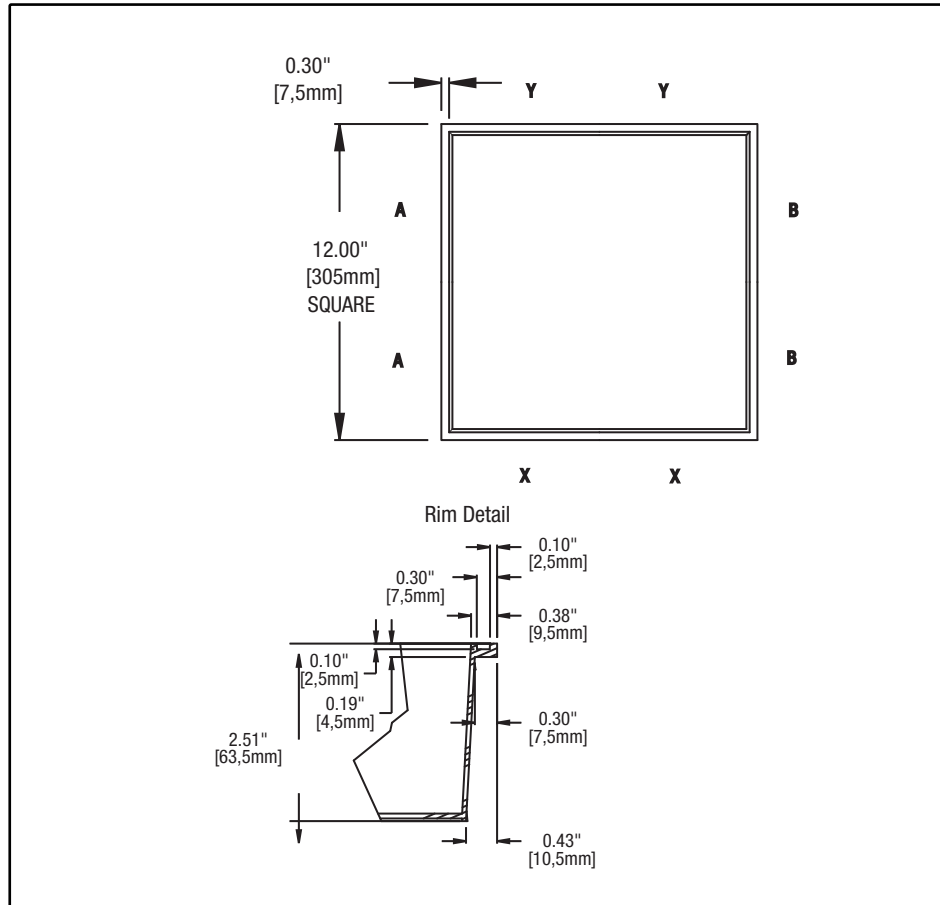

This drawing is for reference only. Actual part dimensions will vary. Customer is urged to review actual samples to confirm fit and function. All specifications and dimensions are subject to change without notice.

***Effective June 30, 2010, lenses associated with this product will no longer be UL recognized components. A.L.P. LexaLite recommends the use of open rated lamps with any polymeric lens. These lenses should not be used as arc retention devices.**