

2675/A/42

MORSETTO PER APPARECCHI DI ILLUMINAZIONE
TERMINAL BLOCK FOR LIGHTING FIXTURES

Dati tecnici

Technical data

| | |
|---|-----------------|
| - Poli - Poles | 4P+T |
| - Corrente e tensione nominale - Rated current and voltage | 16A-450V |
| - Temperatura massima di funzionamento (IEC) - Maximum operating temperature (IEC) | T85 |
| - Grado di protezione - Protection index | IP20 |







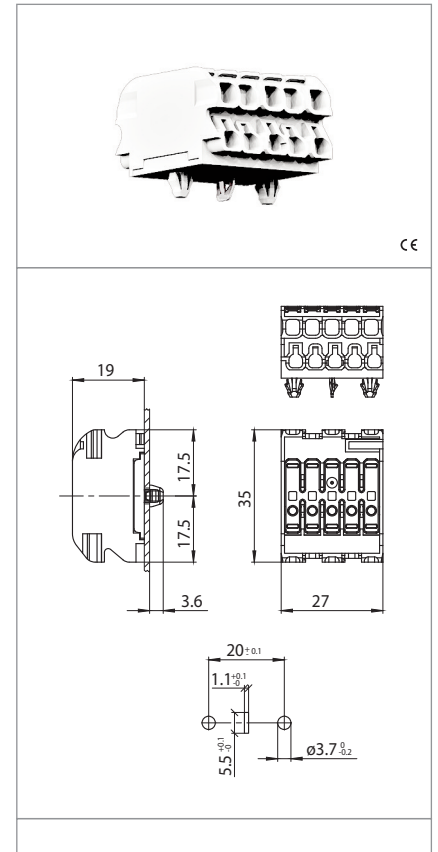

Caratteristiche

Characteristics

- Corpo in policarbonato bianco
– White polycarbonate body
- Corpo serrafiolo in rame/acciaio stagnato
– Internal part in tin plated copper/steel
- Connessione di terra in bronzo
– Earth connection in bronze

Per specifiche cavetti vedi info tecniche del capitolo
For wires' specs. see the chapter technical info



| | | | | | | | |
|--|---|---|--|--|--|--|---|
|  fissaggio ad innesto <i>push-in fixing</i> |  spessore lamiera di fissaggio <i>fixing metal plate thickness</i> 0,4-1,25 |  |  |  | | | |
| serrafiolo lato superiore <i>upper side terminals</i> | SERRAFILO <i>TERMINALS</i> | serrafiolo lato inferiore <i>lower side terminals</i> | | | | | |
| spelatura cavetti cordati, solidi e flessibili <i>stranded, solid and flexible wires stripping</i> |  9-10 | sezione conduttore cordato solido e flessibile <i>stranded, solid and flexible conductor section</i> |  0,5-2,5 mm ² |  1,5-2,5 mm ² | sezione conduttore cordato e solido <i>stranded and solid conductor section</i> |  9-10 | spelatura cavetti <i>wires stripping</i> |

Marchi di qualità
Quality marks

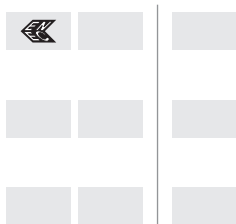

Direttive Europee
European directives

Conforme "RoHS"
"RoHS" compliant
Non soggetto alla "RAEE"
Not subject to "WEEE"

Pesi e confezioni
Weights and packaging

| Art. Codice prodotti <i>Product references</i> | g Peso netto <i>Net weight</i> | n° pz per sacco <i>per bag</i> | n° pz per scatola <i>per box</i> | n° pz per cartone <i>per carton</i> |
|--|--------------------------------------|--------------------------------------|--|---|
| 2675/A/42 | 15 | | 500 | |
| | | | | |
| | | | | |
| | | | | |
| | | | | |

Note

Notes

Note
Note

ISTRUZIONI DI MONTAGGIO

ASSEMBLING INSTRUCTIONS

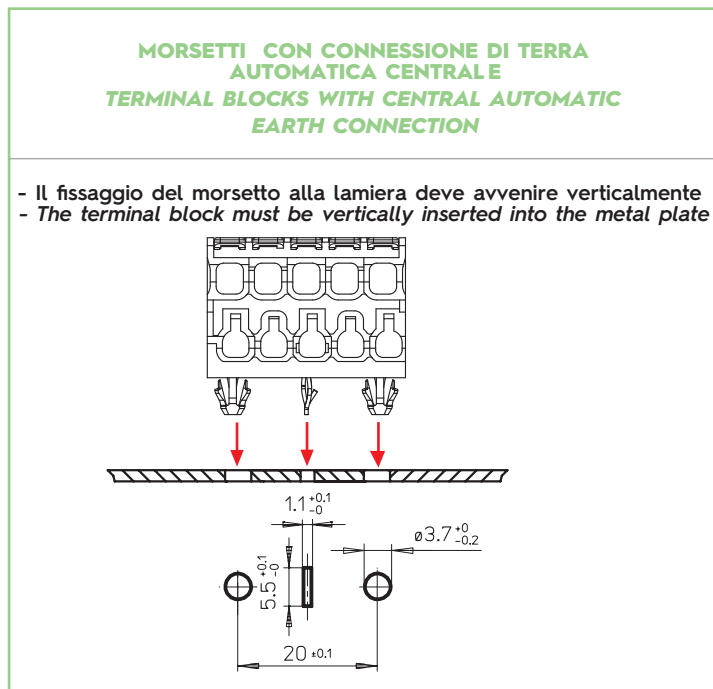

SERRAFILO AUTOMATICO DEGLI ART. 2675/...

PUSH WIRE TERMINALS OF ART. 2675/...

