

SECURITY LENSES

Series I44 / F44 and F49



Series I44-F44

Description

These security lenses will protect the light source against abuse. The added thickness of UV stabilized polycarbonate enhanced by the prism design produces a high quality lens.

1 Lite and 2 Lite versions are available, with and without gaskets. The Series I44 is injection molded. The F44 and F49 are pressure formed. The Series F49 is a deeper (4-1/2") lens.

Application

The F44 and F49 diffusers are manufactured using .177" thick clear polycarbonate with pyramidal prism design on the bottom and vertical perimeter rib for maximum light control and efficiency.

The I44 is injection molded from clear polycarbonate and has prisms on both the inside and outside for superior lamp hiding ability.

For use in high vandal risk locations like

schools, public housing complexes, parking garages, hospitals, police precincts and recreational facilities.

Lamp Data

Series I44/F44 and F49 components are available in one lamp and two lamp designs. These designs are capable of being used with linear or horizontal fluorescent lamps.

Ordering Information

Please call 877-257-5841 for price and delivery. Specify size and mounting holes when placing an order. Custom colors and materials may be provided. Typical lead time is four to six weeks.

Notice

A.L.P. Lighting Components assumes no responsibility for suitability of luminaires and applications. The use of lenses at temperatures near or above 90°C with high ultraviolet output light sources will cause degradation of the material.

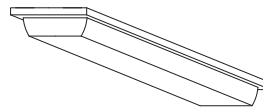

Series I44/F44 and F49

1 Lite

2 Lite

SECURITY LENSES FOR
COMMERCIAL AND
INSTITUTIONAL APPLICATIONS

MATERIAL: CLEAR POLYCARBONATE

PLEASE INQUIRE FOR
FURTHER MATERIAL OPTIONS



Series I44 / F44 and F49

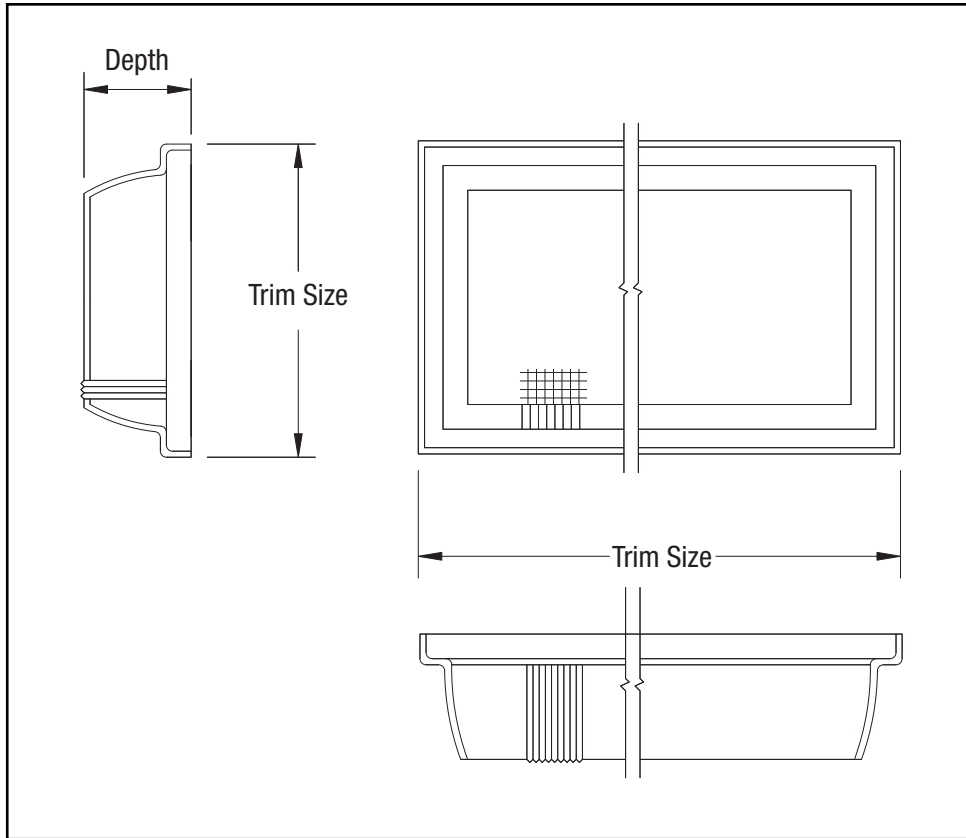

**This drawing is for reference only. Actual part dimensions will vary.
Customer is urged to review actual samples to confirm fit and function.
All specifications and dimensions are subject to change without notice.**

Series I44 / F44 Security Lenses

Part	Description	Trim Size	Depth
F44	1 Lite	4-7/8" x 51"	4-3/4"
F44	2 Lite	9-1/2" x 27"	3-1/4"
I44/F44	2 Lite	9-1/2" x 51"	3-1/4"
F44	1 Lite w/gasket	4-7/8" x 51"	4-3/4"
F44	2 Lite w/gasket	9-1/2" x 27"	3-1/4"
I44/F44	2 Lite w/gasket	9-1/2" x 51"	3-1/4"

Series F49 Security Lenses w/KO's

Description	Trim Size	Depth
2 Lite with KO's	9-1/2" x 27"	4-1/2"
2 Lite with KO's	9-1/2" x 51"	4-1/2"
2 Lite with KO's and Gasket	9-1/2" x 27"	4-1/2"
2 Lite with KO's and Gasket	9-1/2" x 51"	4-1/2"

Materials

The following materials are used in the production of sheet, profiles, formed and molded parts by A.L.P. Plastics. Please be aware that A.L.P. Plastics does not provide material certifications unless requested by the customer prior to quoting. Our standard manufacturing practice includes the use of reclaimed materials exceeding 25%. The I44 uses less than 25% regrind. A material certification can be supplied for the I44 upon request.

Polycarbonate:

General Electric Co.- UL file #E121562, Materials: Lexan ML-7135, 223 and 243.

General Electric Co.- UL file #E61257, Material: Lexan 9034 (Sheet).

Bayer Corp. - Plastics - UL file #E33640, Materials: Makrolon 1804, 2623 and 3123, HF1130.

Mitsubishi - UL file #E41179 Iupolon E2000V.

Teijin - UL file #E50075 Panlite LV-2250Z. Please visit our web site for the most current material specifications.